

# PBV20-25N Series

Platform Power Pallet & Double Pallet Handler  
AC Power • **2.0 – 2.5 tonnes**

**PBV20N  
PBV20ND  
PBV25NH**

## Stepping up productivity... however demanding the job

These compact but sturdy platform power pallet trucks deliver high productivity within a wide range of complex and demanding applications. Thanks to the AC technology of their drive motors, maintenance requirements are minimal while power, control, comfort and energy efficiency are high. The state-of-the-art, simple-to-use tiller arm design protects hands and places everything within easy reach for safe, comfortable, controlled operation.

Both standard (PBV20N) and heavy duty (PBV25NH) models are available to meet different needs. The PBV25NH is designed to withstand non-stop, intensive use, over longer distances, with the heaviest loads. It will reach a top speed of 8 km/h. The standard PBV20N is ideal for pallet transfer work - involving distances over 50 m - in logistics terminals, industrial warehouses and other business premises, as well as loading and unloading vehicles. There is also an ingenious double pallet model (PBV20ND) which can handle two pallets at once. Ideal for loading and unloading double-deck stacked pallets, it will also transport loads at speeds up to 12 km/h.

### Frame and body

- **Robust construction** offers exceptional durability in all working conditions.
- **Low centre of gravity** means stable, safe operation.
- **High-visibility design** maximises view of fork tips and working area.

### Forks

- **Reinforced forks** - on PBV25NH - give extra strength to cope with intense work and heavy loads.
- **Tapered forks** ensure smooth pallet entry and exit.
- **Compact duplex mast** offers two lift heights (1600 and 2000 mm), with maximum load capacity 2000 kg (or 1000 kg on each pair of forks), and gives optimal forward visibility. (PBV20ND only)



# PBV20-25N Series

## Platform Power Pallet & Double Pallet Handler

### AC Power • 2.0 – 2.5 tonnes

Characteristics					
1.1	Manufacturer (abbreviation)		Mitsubishi	Mitsubishi	Mitsubishi
1.2	Manufacturer's model designation		PBV20N	PBV25NH	PBV20ND
1.3	Power source: (battery, diesel, LP gas, petrol)		Battery	Battery	Battery
1.4	Operator type: pedestrian, (operator)-standing, -seated		Pedestrian/Stand-on	Pedestrian/Stand-on	Pedestrian/Stand-on
1.5	Load capacity	Q (kg)	2000	2500	1000 + 1000
1.6	Load centre distance	c (mm)	600	600	600
1.8	Load wheel axle to fork face (forks lowered)	x (mm)	960	980	946
1.9	Wheelbase	y (mm)	1385	1528	1553
Weight					
2.1	Truck weight with nominal load & maximum battery weight	kg	2742	3468	3270 2)
2.2	Axle loadings with nominal load & maximum battery weight, drive/load side	kg	1053/1689	1214/2254	1270/2000 2)
2.3	Axle loadings without load & with maximum battery weight, drive/load side	kg	600/142	752/216	920/350 2)
Wheels, Drive Train					
3.1	Tyres: PT=Power Thane, Vul=Vulkollan, drive/load side		Vul/Vul	Vul/Vul	Vul/Vul
3.2	Tyre dimensions, drive side	(mm)	230x70	230x105	230x70
3.3	Tyre dimensions, load side	(mm)	85x75	85x90	85x75
3.4	Castor wheel dimensions (diameter x width)	(mm)	150x50	150x50	150x50
3.5	Number of wheels, drive/load side (x=driven)		2+1x/4	2+1x/4	2+1x/4
3.6	Track width (centre of tyres), drive side	b10 (mm)	550	550	550
3.7	Track width (centre of tyres), load side	b11 (mm)	385	385	385
Dimensions					
4.4	Lift height (see tables)	h3 (mm)	115	135	1600,2000
4.9	Height of tiller arm / steering console (min./max.)	h14 (mm)	1157/1349	1157/1349	1157/1349
4.14	Height of the driver's platform	h12 (mm)	145	145	145
4.15	Fork height, fully lowered	h13 (mm)	85	85	92
4.19	Overall length	l1 (mm)	1839/2295	1962/2417	2037/2493
4.20	Length to fork face (includes fork thickness)	l2 (mm)	689/1145	812/1267	887/1343
4.21	Overall width	b1/b2 (mm)	790	790	790
4.22	Fork dimensions (thickness, width, length)	s / e / l (mm)	50/165/1150	60/185/1150	56/185/1150
4.25	Outside width over forks (minimum/maximum)	b5 (mm)	550	550	570
4.32	Ground clearance at centre of wheelbase, (forks lowered)	m2 (mm)	35	25	25
4.33a	Working aisle width (Ast) with 1000 x1200 mm pallets, load crosswise, platform up/down	Ast (mm)	2315/2751	2448/2886	2637/2932
4.33b	Working aisle width (Ast3) with 1000 x 1200 mm pallets, load crosswise, platform up/down	Ast3 (mm)	1909/2345	2029/2467	2089/2525
4.34a	Working aisle width (Ast) with 800 x1200 mm pallets, load lengthwise, platform up/down	Ast (mm)	2335/2771	2466/2904	2509/2945
4.34b	Working aisle width (Ast3) with 800 x 1200 mm pallets, load lengthwise, platform up/down	Ast3 (mm)	2109/2545	2229/2667	2289/2725
4.35	Turning circle radius 4.35 Wa (mm)	Wa (mm)	1669/2105	1809/2247	1835/2271
Performance					
5.1	Travel speed, with/without load	km/h	9.0/9.0 (12.0 1)	8.0/8.0 (12.0 1)	8.5/8.5
5.2	Lifting speed, with/without load	m/s	0.027/0.038	0.027/0.035	0.15/0.22
5.3	Lowering speed, with/without load	m/s	0.052/0.029	0.076/0.041	0.26/0.21
5.7	Gradeability, with/without load	%	10/20	9.0/20.0	7/15
5.10	Service brakes (mechanical/hydraulic/electric/pneumatic)		Electric	Electric	Electric
Electric motors					
6.1	Drive motor capacity (60 min. short duty)	kW	2.0	2.0	2.0
6.2	Lift motor output at 15% duty factor	kW	1.0 (10%)	1.2 (10%)	2.2 (10%)
6.4	Battery voltage/capacity at 5-hour discharge	V /Ah	24/270,375	24/375,500	24/375
6.5	Battery weight	kg	240,295	315,390	285
Miscellaneous					
8.1	Type of drive control		Stepless	Stepless	Stepless

Continuing improvement may lead to changes in these specifications.

Options: (1) Higher travel speed – 12 km/h with loads up to 600 kg. 2) = D2000

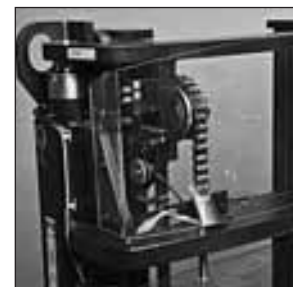

Compact duplex mast

PBV20ND				
Mast type	h3+h13 mm	h1* mm	h4* mm	h2+h13 mm
Duplex	1600	1371	2101	(155)
	2000	1571	2501	(155)

#### PBV20N and PBV25NH

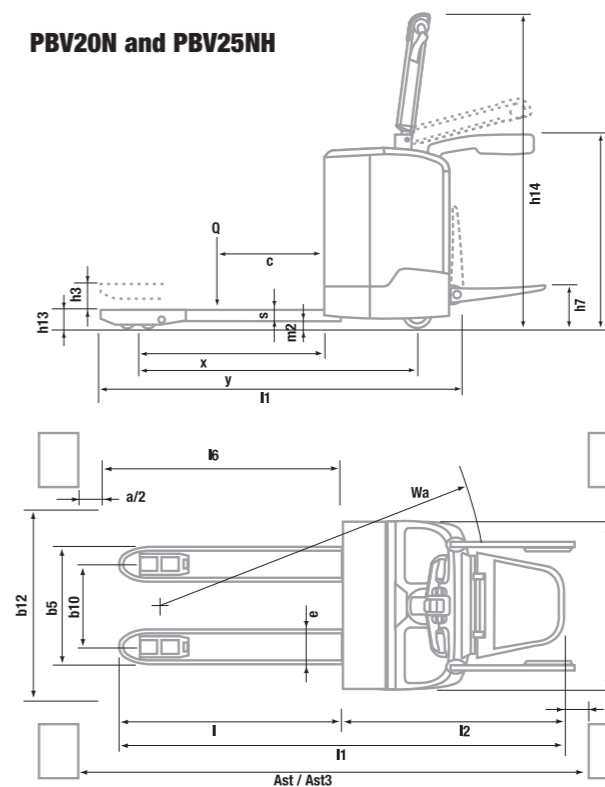

#### PBV20ND

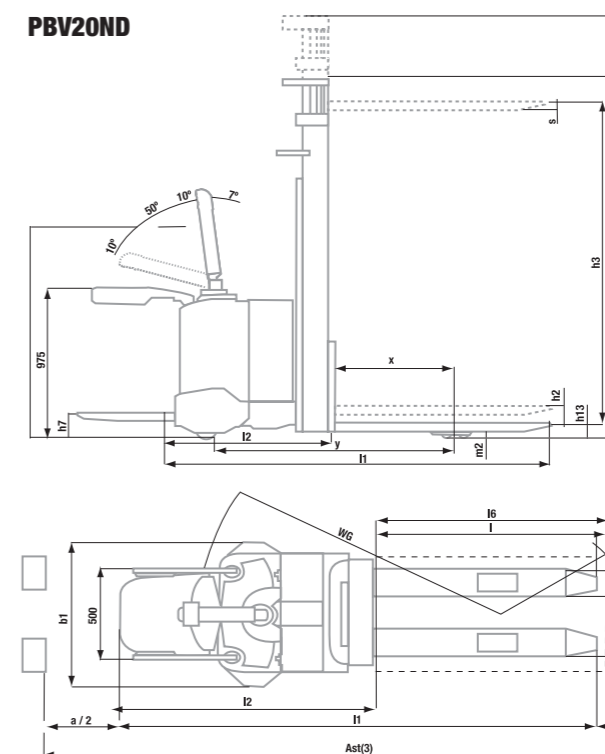

Ast = Working aisle width  
 Ast3 = Working aisle width (b12 ≤ 1000 mm)  
 $Ast = Wa + \sqrt{(l6 - x)^2 + (b12 / 2)^2} + a$   
 Ast3 = Wa + l6 - x + a  
 Wa = Turning radius  
 l6 = Pallet length  
 x = Load wheel axle to fork face  
 b12 = Pallet width  
 a = Safety clearance = 2 x 100 mm



Ergonomic tiller arm



Built-in charger



Easy-view display



Creep speed function



Cushioned sidebars



High-capacity batteries



Clear display

## Drive

- **AC drive motor** means high power for excellent traction and ramp performance, as well as smooth, quiet, controlled operation, extended shift length and lower maintenance requirements.
- **Load sensing system** optimises drive wheel pressure on floor as load increases, to deliver outstanding traction and ramp performance.
- **High-capacity ventilation equipment** – on PBV25NH – allows non-stop use without overheating the drive unit and electrical systems, even in environments with high temperatures.
- **Floating drive unit** reduces vibration, for greater operator comfort and lower maintenance requirements.
- **Wider drive wheel** – on PBV25NH – means less wear and better grip.

## Steering system

- **State-of-the-art tiller arm** offers the ultimate in ergonomic design, comfort and safety.
- **Small turning circle** – together with compact chassis and excellent visibility – means exceptional manoeuvrability.

## Brakes

- **Regenerative braking** means effective control and reduced brake wear.
- **Automatic braking** improves safety and control on ramps.

## Electrical and control systems

- **Programmable controller** adjusts acceleration, travel speed and braking to suit the application and driver – for great versatility.
- **On-board diagnostics and fault memory folder** speed up servicing and help prevent damage.
- **High-capacity batteries** – 270-375 Ah standard and 375-500 Ah for PBV25NH – extend shifts.
- **Battery rollers and fast battery lock** – standard on PBV25NH – ensure rapid changeovers.
- **Lateral battery change** speeds up changeovers.

## Operator environment and controls

- **Creep speed function and tiller arm lock bypass** are included as standard for maximum control and safety in confined areas.
- **Large, suspended platform** stays down for easier access and – together with high-positioned, cushioned sidebars – provides a safe, ergonomic standing position.

- **High-grip rubber matting** prevents slips and gives cushioned comfort.
- **Clear display** alerts operators and service engineers to potential problems – helping to avoid damage and encourage maintenance.

## Other features

- **Long service interval** reduces downtime and maintenance bills.
- **Rapid access features** give quick and easy entry to all areas for checks and maintenance.
- **Dust-shielded load wheels** require less maintenance and replacement of components.

## Options

- **Electric steering**
- **PIN-code device** instead of key switch
- **Higher travel speed** on PBV20-25N(H) – 12 km/h with loads up to 600 kg
- **Cold storage modification** (class III, -35°C)
- **Fixed platform with backrest** or fixed side rests.
- **Rollers for easy pallet entry**
- **Wide variety of fork dimensions**
- **Customer name/logo/artwork** on side panels
- **Load weight indicator**
- **Choice of wheel materials** for different applications
- **Load backrest**



Double pallet handler  
PBV20ND

when  
**reliability**  
is **everything**

Developed for outstanding performance and genuine value for money, the awardwinning\* range of Mitsubishi forklift trucks and warehouse equipment is built to a higher specification to maximize productivity and ensure utter reliability... whatever the application.

It's what you'd expect from one of the world's largest corporations whose companies are at the leading edge of technologies where performance, quality and dependability can never be compromised.

It means that, from a single safe source, we can meet 98% of all handling requirements, supplied to you via a range of competitive finance options including outright purchase, rental or leasing. So your local dealer can advise you on precisely the right product for your application... and your budget.

Moreover, because we understand how much you depend on your Mitsubishi forklift truck, we deliver the highest levels of customer support.

Through a network of carefully selected dealerships, we provide quality maintenance and customer care programmes including a choice of warranties that give complete peace of mind. Every dealership holds extensive stocks of manufacturer-approved parts, backed by a central store that holds literally millions of items constantly in stock and achieves a first-pick fulfilled rate of 97%. So your truck can be fixed first time, virtually every time.

\* Mitsubishi Forklift Trucks has won **four** separate Fork Lift Truck Association Annual Awards for Excellence covering the areas of **Ergonomics, the Environment and Innovation.**



WESM0986 (04/08)  
© 2008 MCFE  
Printed in The Netherlands

[mitforklift@mcf.nl](mailto:mitforklift@mcf.nl)  
[www.mitforklift.com](http://www.mitforklift.com)

NOTE: Performance specifications may vary depending on standard manufacturing tolerances, vehicle condition, types of tyres, floor or surface conditions, applications or operating environment. Trucks may be shown with non-standard options. Specific performance requirements and locally available configurations should be discussed with your distributor of Mitsubishi forklift trucks. Mitsubishi follows a policy of continual product improvement. For this reason, some materials, options and specifications could change without notice.